

radarTOUCH NEO



Manual Version 1.1



Date	Revision No.	Author	Description
22.01.2026	1.0	TSN	
15.04.2026	1.1	LVN / TSN	new mounting version



Note: This manual is subject to change without further notice. The latest manual version can be found online at www.exactsolutions.de or by contacting us directly.

Contact

Tel.: +49 2204 9485 30

E-Mail: info@exactsolutions.de

Web: www.exactsolutions.de

Table of content

1. Preamble	3
1.1 Tools required.....	3
2. Safety instructions	4
2.1 Warnings.....	4
2.2 Laser safety note	6
3. Scope of delivery	7
4. Optional Accessories	8
5. Description of the product	9
5.1 Intended use	9
5.2 Restrictions in usage	9
5.3 Measurement device overview	10
5.4 Specifications	11
5.5 Front LEDs.....	13
5.5.1 Trouble shooting.....	15
6. Integration	16
6.1 Measurement principle	16
6.2 Mechanical Integration.....	18
6.2.1 Deluxe mounting system	19
6.2.2 Standard mounting system	23
6.3 Connection.....	26
7. The radarTOUCH Software	27
7.1 Graphical user interface	27
7.1.1 The PreViz	30
7.1.2 MultiBlobViz	31
7.1.3 The Info-Window	32
7.2 Output interfaces.....	32
7.2.1 Mouse Emulation.....	32

7.2.2 Open sound control (OSC): TUIO	33
7.3 XML Files	33
7.3.1 Setting files	34
7.3.2 Configuration file	35
8.0 Configuration Tool.....	38
8.1 Changing network settings	38
8.2 Changing angular resolution and scan frequency	39
8.3 Check Status	39
8.4 Reset Network Settings	40
8.5 Get Error Log.....	41
9 Integration	42
9.1 Best way of mounting.....	42
9.2 Concealing the measurement device	44
9.3 Calibration and Adjustment.....	44
10 Appendix.....	46
10.1 Changing the IP address of your computer	46
10.2 User interface design.....	48
11 Disposal of components	49
11.1 Metal parts and packaging	49
11.2 Disposal of entire devices.....	49
Imprint.....	49

1. Preamble

The radarTOUCH system has been developed and manufactured with the highest care and attention. However, improper handling can cause a risk for safety and / or damage. Read these instructions carefully before handling and installing the product so that you can safely enjoy your device. In the following pages, you will find all the needed information for a safe and fast installation.

Model number: radarTOUCH NEO

Copyright © 2025 EXACT solutions GmbH. All rights reserved.

1.1 Tools required

The following tools are required depending on the mounting system:

- 4 mm hex key to mount the measurement device to the mounting bracket
- 2,5 mm hex key to fix the mounting bracket to the Deluxe or Standard Mount

Additionally, if using Deluxe Mount with CLP50:

- 3 mm hex key and 8 mm wrench to fix the deluxe mount to the CLP50

2. Safety instructions



These installation instructions must always be handed over to the person who is carrying out the installation.

Read these instructions carefully before installing the system.

2.1 Warnings



The radarTOUCH NEO is intended for use by fully qualified, trained and competent persons to provide safe and secure transportation, installation and adjustment of projectors.



Warning: Handling only by instructed, qualified and authorised person with a minimum age 18 years and of sound mind.



Do not open the housing!

Definition Trained/Qualified person

A person can be considered as trained/qualified when it has been thoroughly informed and/or trained about the assigned task and the possible dangers that can occur in case of improper behaviour and / or not observing precisely the installation instructions.

Furthermore that person must fulfil the following requirements:

- They have appropriate technical training.
- They are familiar with the regulations and rules regarding occupational safety and workplace security.
- They are familiar with the device's operating manual.
- They have been instructed by the responsible personnel on the assembly and operation of the device.

Manual radarTOUCH NEO

Only use the radarTOUCH and its components for its intended use.

- If this product is used for something else than its intended use, serious accidents and death may result. See chapter 5.1 Intended use

Service work shall only be done by the manufacturer.

- Unauthorized personnel shall never do service work on the products, as service work requires special training and knowledge
- Not observing these rules on service work ends with immediate effect the responsibility of the manufacturer and, where applicable, warranty is irrecoverably lost. The product is no longer safe to use.

Use only gentle cleaning agents to avoid damage. Act carefully

- Cleaning of the optical window may be done with a clean and damp cloth
- Do not use any aggressive products to clean the optical window
- Avoid rubbing the dirt on the optical window to avoid scratches

Incorrect disposal is a risk to humans and nature

- Disposal must be done in accordance with local laws and regulations. Contact the manufacturer in case of any questions.

Keep the measurement device permanently powered in environments where the temperature can be below 0 °C.

- Otherwise correct functionality can not be guaranteed

Make sure that the structure to which the system will be mounted is stable and strong enough to carry the overall weight

- Incorrect installation may lead to certain parts of the system to fall down causing a hazard for peoples life.
- Only qualified persons should do the installation
- Double check the radarTOUCH system and its installation.

Use correct screws and dowels to fix the mounting systems so an onsite structure

- Only correct screws and dowels that are suitable for the onsite structure (wall, ceiling etc) ensure a safe installation
- Using wrong mounting materials can causes serious injuries and death.

Make sure to avoid the following:

- Avoid extreme vibrations
- Avoid the presence of smoke, fog or light sources (also Infrared) in the measurement field
- Avoid condensation
- Avoid exposure to sudden and extreme temperature changes
- Avoid direct exposure to high pressure cleaning
- Avoid mirror like, reflective, surfaces in the area of the laser

2.2 Laser safety note

ATTENTION, INVISIBLE LASER RADIATION – LASER CLASS 1

The device fulfills the EN 60825-1:2007 safety regulations for a product in laser class 1 as well as the U.S. 21 CFR 1040.10 regulations with deviations corresponding to "Laser Notice No. 50" from June 24th, 2007.

Observe the applicable statutory and local laser protection regulations.





The device must not be tampered with and must not be changed in any way. There are no user-serviceable parts inside the device.

Repairs must only be performed by the manufacturer.





3. Scope of delivery



Note: Please check the delivery for completeness and damage immediately after you receive the shipment. Please contact your vendor in case of missing or damaged parts.

	radarTOUCH NEO Measurement device
	Power supply cable and mains adapter Art Nr: RTOUCH-NEO-PWRCBL
	Ethernet Cable Art Nr: RTOUCH-NEO-ETHCBL
	Software Art Nr: RTOUCH-NEO-DONGLE  The dongle is the license. Take care for it and make sure to not lose it.
	User manual and installation guide

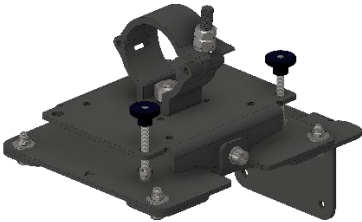
4. Optional Accessories

	<p>Deluxe Mount for ceiling mount Art Nr: RTOUCH-NEO-DLX-CB Incl: 4 x Screw DIN 912 M5x12 4 x Schnorr safety washer for M5</p>
	<p>Deluxe Mount for truss mount Art Nr: RTOUCH-NEO-DLX-CLP50 Incl: 4 x Screw DIN 912 M5x12 4 x Schnorr safety washer for M5</p>
	<p>Standard Mount Art Nr: RTOUCH-NEO-STD Incl: 4 x Screw DIN 912 M5x12 4 x Schnorr safety washer for M5</p> <p>NOTE: This is product is end of life</p>
	<p>Standard Mount Small Art Nr: RTOUCH-NEO-STD-S Incl: 4 x Screw DIN 912 M5x12 4 x Schnorr safety washer for M5</p>

 The optional accessories must be purchased separately. They are not included in the standard package!

5. Description of the product

5.1 Intended use

Only operate the device in accordance with its intended use. The protection of personnel and the device cannot be guaranteed if the device is operated in a manner not complying with its intended use.



EXACT solutions GmbH is not liable for damages caused by improper use. Read the technical description before commissioning the device. Knowledge of this technical description is an element of proper use.



Comply with conditions and regulations!
Observe the locally applicable legal regulations and the rules of the employer's liability insurance association.

The radarTOUCH NEO is designed and intended for enabling interactivity on large surfaces. The surface can be vertical or horizontal or something in between. Furthermore the surfaces can be all sort of screen such as DV LED, projection, LCD etc.

The measurement device is a 2D laser scanner that scans a single plane and sends those measuring data by network connection to the radarTOUCH driver.

5.2 Restrictions in usage

- Glass, highly reflective materials such as mirrors and objects that do not reflect light back to the sensor can falsify the reading.
- Do not expose the radarTOUCH NEO sensor to flying sparks (e.g. welding sparks); the front cover and other parts of the system could be damaged.
- Vapours, smoke, dust and all visible particles in the air can affect the measured values
- If a protective housing is provided for the sensor, it must not be covered by additional window material (plastic, glass, etc.).

5.3 Measurement device overview

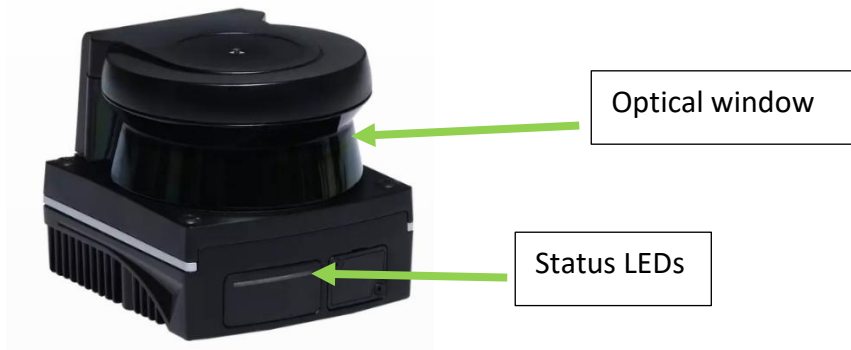

Figure 1 Measurement device front view

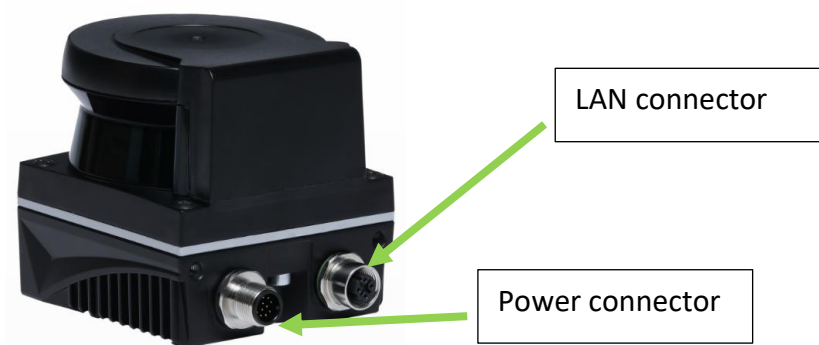

Figure 2 Measurement device rear view

5.4 Specifications

Parameter	Specification
Technology	Laser scanner, time-of-flight measurement
Optical characteristics	IR LASER: wavelength 905 nm; Output power < 0.1 mW; Class 1 (IEC/EN 60825-1)
Scanning angle	180°
Angular resolution and scanning frequency	0,1 ° at 40 Hz or 0,2 at 80 Hz
Scanning range	0.08 – 25 m; 7 m @ 1.8% reflectivity; 15 m @ 10% reflectivity
Light spot size Diameter of the light spot Beam divergence	11 mm x 7 mm @ 1 m (at 90% spot energy) 8 mm/m (longitudinal) x 2 mm/m (transversal)
Flatness of scanning plane	± 0.2°
Measurement Accuracy Systematic Error Statistical Error (1σ)	± 20 mm* ≤ 6 mm (0.08–7 m); ≤ 10 mm (7 – 10 m); ≤ 15 mm (10 – 15m)*
Electrical Specifications Supply Voltage Power Consumption	12 – 24 V DC, -10% / +30% < 5.5 W
Interfaces Ethernet Default IP Address Port	UDP/IP 192.168.60.3 3050

Manual radarTOUCH NEO

Mechanical Specifications	
Degree of Protection	IP67 (only with the USB port cover in place, IEC 60529)
Dimensions	73.8 mm (H) x 80.2 mm (W) x 85.5 mm (D) (not including connectors)
Weight	approx. 560 g
Housing Material	Zinc / Plastic
Optical Window Material	Plastic / PC
Connection Type	1 x Power/output, 5-pin, M12 male connector, A-coded 1 x Ethernet, 4-pin, M12 female connector, D-coded
Ambient conditions	
Operating temperature	- 30 °C to + 60 °C
Storage temperature	- 40 °C to + 70 °C
Relative humidity	< 95%, non-condensing
Ambient light immunity	100 000 lux (ambient light); 3 000 lux (IEC 61496-3)
EMC	
Class of immunity	Industrial environments (IEC 61000-6-2)
Class of emission	Commercial environments (IEC 61000-6-3)

* Typical value at 10% reflectivity up to 7m scanning range or as specified; real values depends on ambient conditions and the target object.

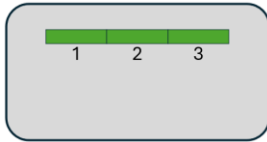

** External electrical sources must ensure double insulation from primary voltages.

5.5 Front LEDs





1. Power Status
2. Ethernet Con.
3. Error Status





LED 1:

LED 1	
	Power off. No supply voltage
	Power on.
	External power supply error

LED 2:

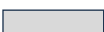
LED 2	
	No ethernet connection
	Ethernet connection established, no measurement data transfer
 Flashes 3x	Ethernet measurement data transmission (default off)

LED 3:

LED 3	
	Power off. No supply voltage
	Normal operation, no error
	Internal error
	Fatal error

Manual radarTOUCH NEO

Contamination warning and error

The LEDs indicate the contamination status of the front window.

LED 1/2/3 flash 1 time / second: Contamination warning left/center/right of the window

LED 1/2/3 flash 3 time / second: Contamination error left/center/right of the window

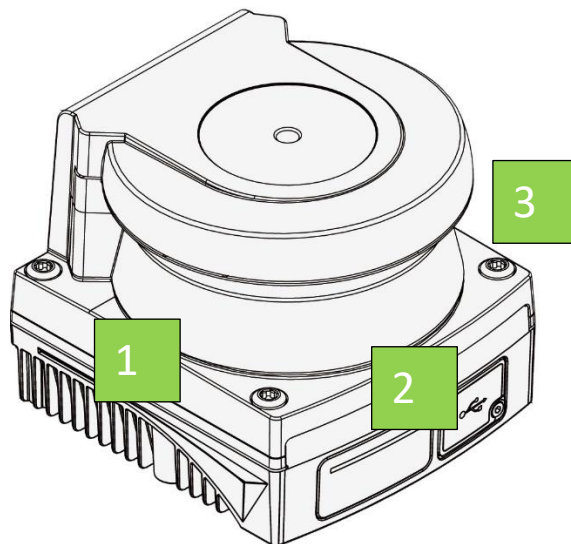

5.5.1 Trouble shooting

LED Status	Issue	Solution
LED 1 is off LED 3 is off.	There is no power.	Check cables and connections.
LED 1 is permanently red.	Power supply is out of limit.	Check the power supply (voltage, capacity).
LED 2 is off.	Ethernet connection is not established.	Check ethernet cable and connections.
LED 2 is permanently green.	Ethernet connection is established, but no measurement data being transferred.	Send the command to start measurement data transfer.
LED 3 is permanently orange.	There is an internal error.	Reboot the device.
LED 3 is permanently red.	There is a fatal error.	Send the laser scanner back for a technical check-up.
LED 1 flashes 1x every 2 seconds.	The left side of the optical window contamination has reached the warning threshold.	Clean the optical window by wiping it with a clean damp cloth.
LED 2 flashes 1x every 2 seconds.	The center of the optical window contamination has reached the warning threshold.	Clean the optical window by wiping it with a clean damp cloth.
LED 3 flashes 1x every 2 seconds.	The right side of the optical window contamination has reached the warning threshold.	Clean the optical window by wiping it with a clean damp cloth.
LED 1 flashes 3x every second.	The left side of the optical window contamination has reached the error threshold.	Clean the optical window by wiping it with a clean damp cloth.
LED 2 flashes 3x every second.	The center of the optical window contamination has reached the error threshold.	Clean the optical window by wiping it with a clean damp cloth.
LED 3 flashes 3x every second.	The right side of the optical window contamination has reached the error threshold.	Clean the optical window by wiping it with a clean damp cloth.

6. Integration

6.1 Measurement principle

The radarTOUCH NEO measurement device is a laser scanner, scanning a flat plane over 180°. The laser has a wavelength of 905nm and measures the distance based on the Time-of-Flight method. It scans with a frequency of 40 Hz and an angular resolution of 0,1° or with 40 Hz and 0,2°. This can be changed in the Configuration Tool see also 8.2 Changing angular resolution and scan frequency.

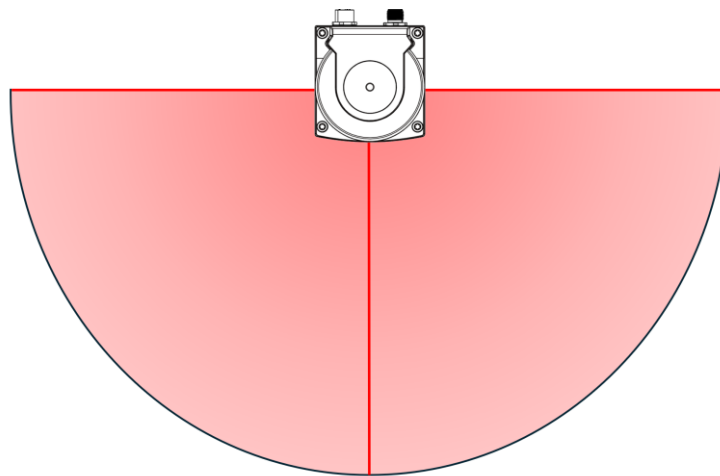
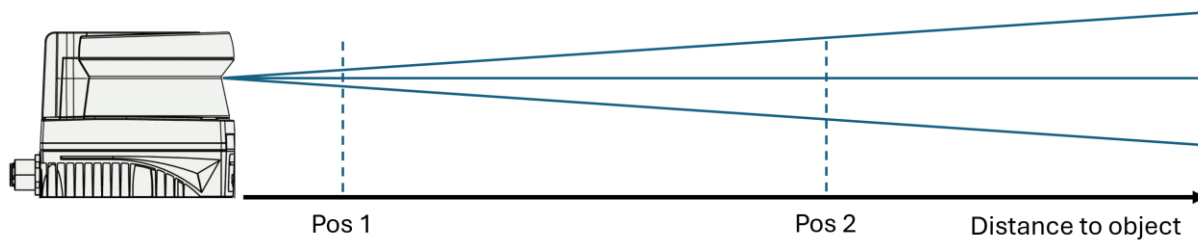

Figure 3 Top view of measurement device scanning over 180°

Manual radarTOUCH NEO

The laser spot has a certain size that widens with increasing distance. Due to this the diameter of the laser spot that hits the surface of an object is also larger. All measurements refer to a size of the spot where 90 % of the laser energy is centred. At a distance of 1m, the laser spot has a size of 11 x 7 mm. This increases with increasing distance.



Pos 1: Distance of 1m Light spot size: 11 mm
Pos 2: Distance of 10m Light spot size: 111 mm

Note: Opening angle is 0,72°

Figure 4 Schematic illustration of laser spot size depending distance

Remission of the object

Remission is not equal to reflexion: it describes a diffuse reflexion. An ideal remitter would remit the light in the same way a Lambert emitter would. The remission must be high enough to give the detecting unit in the measurement device a chance to receive sufficient light. The so called inverse square law describes the fact that the remitted light is reduced by the reciprocal value of the radius. This law makes the importance of the remission obvious.

i Note: With increasing distance, the measurement resolution decreases. Objects with darker surface remit less light energy and by this might not be detected perfectly. Depending on a specific setup, testing is recommended.

Below figure illustrates the working principle of the system.

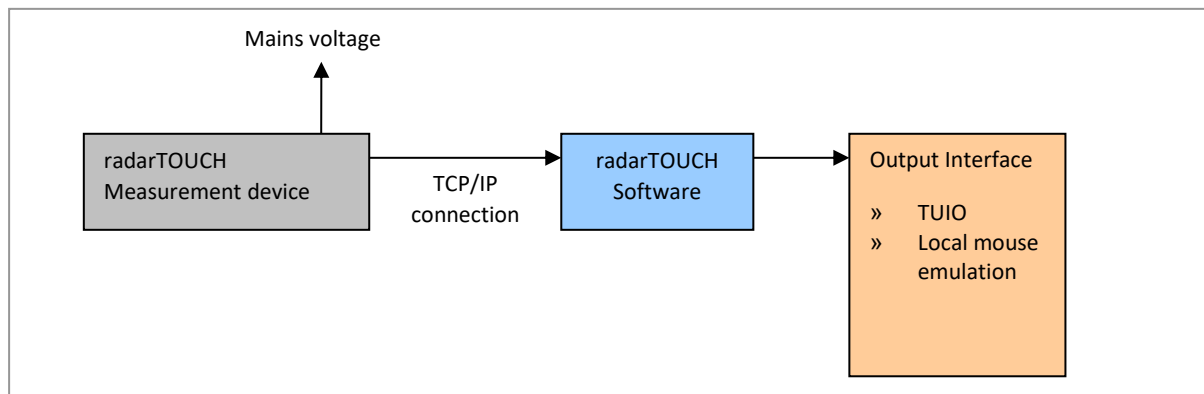

Figure 5 Working principle

6.2 Mechanical Integration

The radarTOUCH measurement device can be installed above or below every vertical surface turning any kind of display or material interactive. The interaction can be similar like with a standard touch device by actually touching the vertical surface or without touching the surface. Interaction free in the air is by this also possible.

If installed horizontally, the device can also scan above the floor and track for example people.



For vertical surfaces we recommend the installation above the surface.



If using an enclosure, the entire front cover of the device must, however, remain unobstructed. The inside of the enclosure should be non reflective and have matte black surface.



Make sure to use correct mounting material to fix the mounting to a wall or ceiling and to fix the measurement sensor to the mounting bracket. Also make sure the supporting structure can carry the overall weight

6.2.1 Deluxe mounting system

 Detailed drawings are available online or on request

With the deluxe mounting system, you can adjust the following parameters:

- Rotation around X, Y and Z Axis
- Distance in Z-direction between the measurement device and for example the screen you are using as active area.

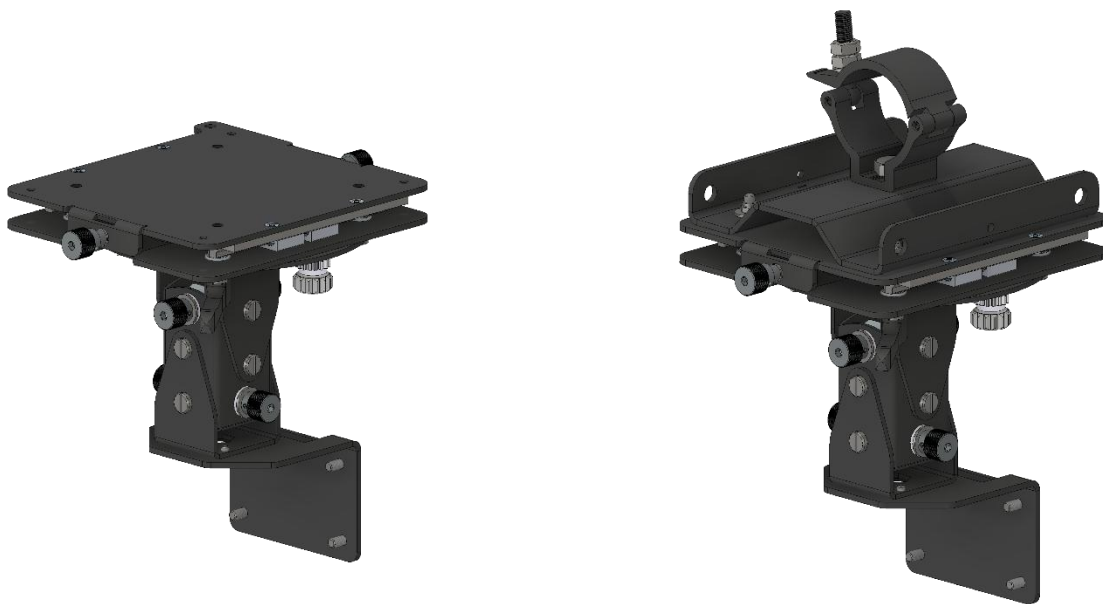

Figure 6 Left: Deluxe Mount for ceiling, right Deluxe Mount with ECO-CLP-50

Figure 6 shows the two different versions of the Deluxe Mount.

- Left Side: Deluxe mount with ceiling mounting bracket [RTOUCH-NEO-DLX-CB]
- Right Side: Deluxe mount with additional truss mounting bracket [RTOUCH-NEO-DLX-CLP50]

Manual radarTOUCH NEO

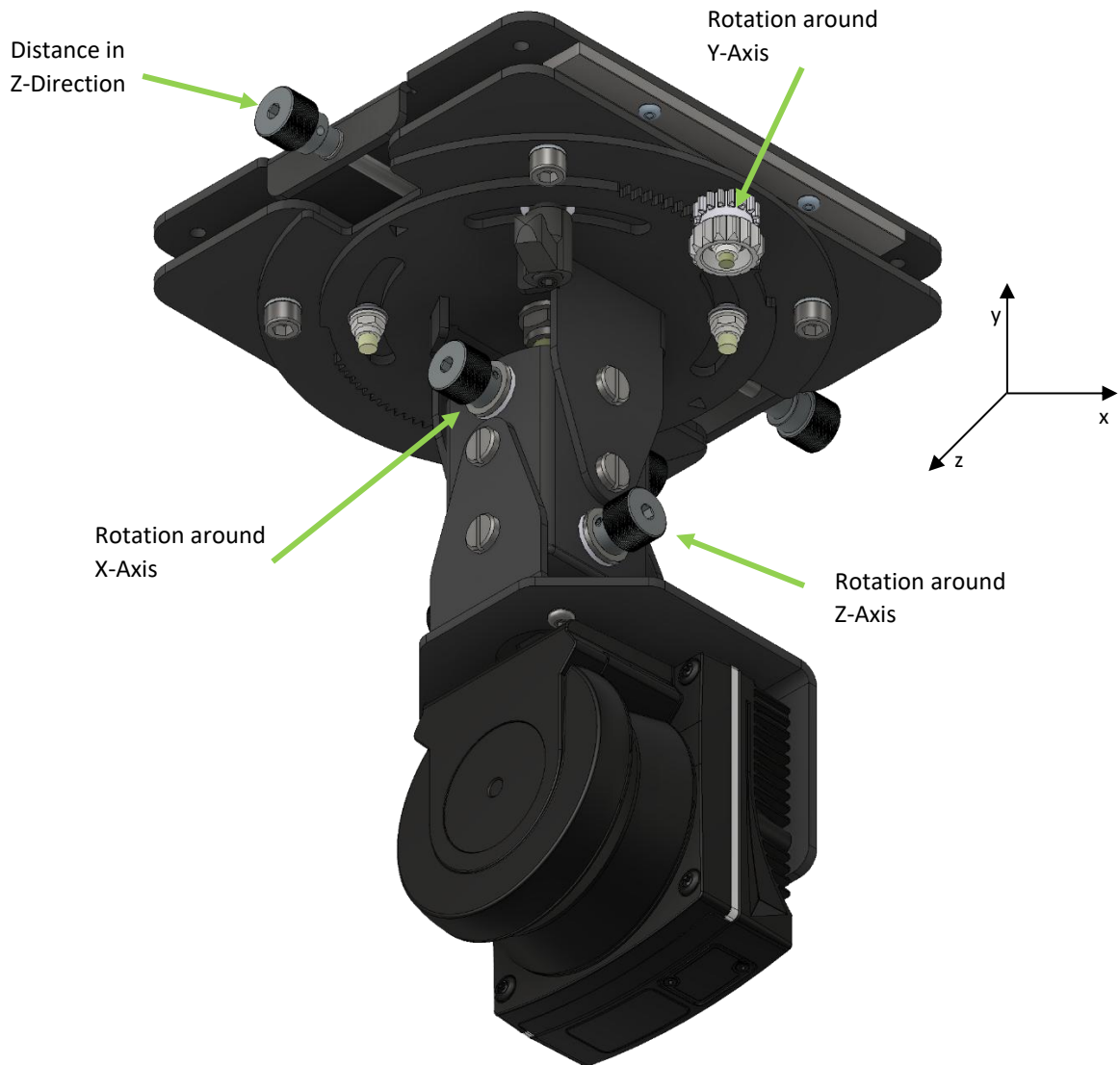

Figure 7 Adjustment features of Deluxe Mounting System

Manual radarTOUCH NEO

To attach the radarTOUCH measurement device to the Deluxe Mounting System, use the four M5 x 12 DIN 912 screws (see Figure 8).

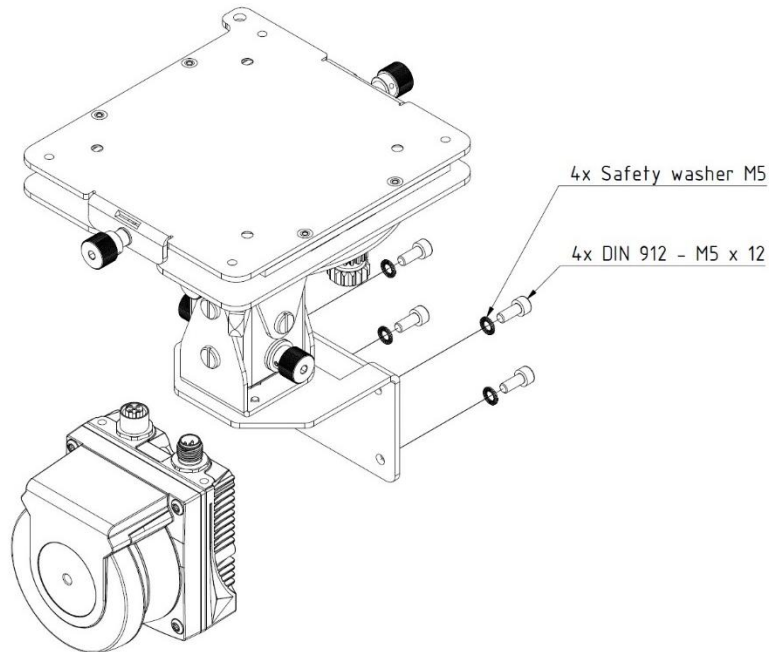

Figure 8 Explosion drawing mounting to Deluxe Mount

The top metal plate of the deluxe mounting system has four 4,5 mm holes to mount it to an onsite ceiling. See Figure 9 for further details. To access the holes, it is necessary to shift the mechanism forward and backward.

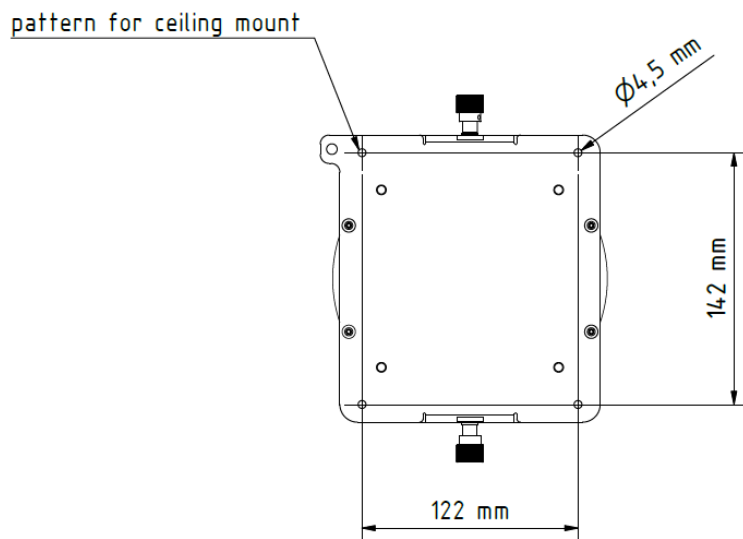

Figure 9 Top metal plate deluxe mount

Manual radarTOUCH NEO

If the installation requires a truss mounting, customers can choose the Deluxe Mount with additional truss mounting bracket (RTOUCH-NEO-DLX-CLP50). This comes with a half coupler for 50mm diameter pipes. See also Figure 6.

Figure 10 shows the assembly of the Deluxe Mount and the CLP50 truss bracket.

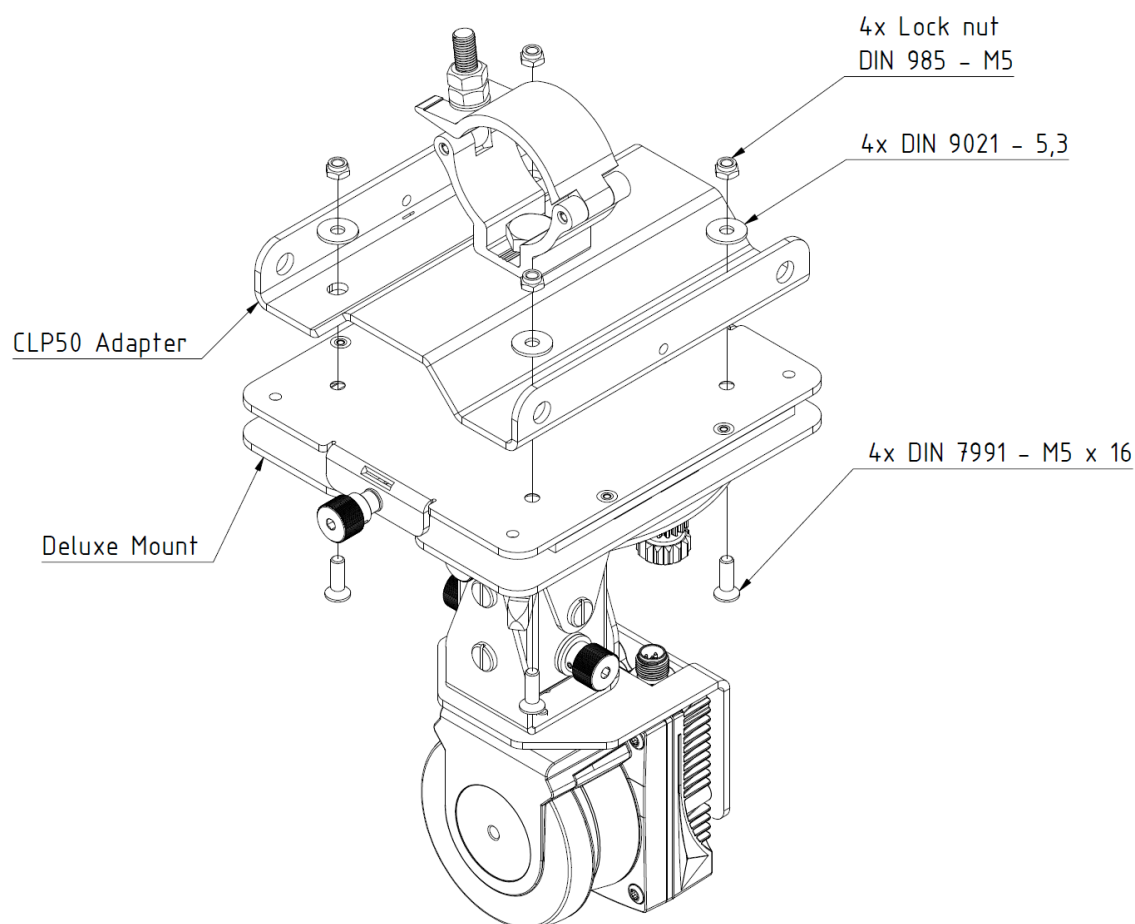

Figure 10 Deluxe Mount with additional CLP50 trussing adapter

6.2.2 Standard mounting system



Detailed drawings are available online or on request



This mounting system is end of life, see the following chapter for the new model.

The standard mounting system is a good solution for some simple applications. However, if the installation requires a very high precision, you should use the deluxe system.

With the standard mounting system, you can adjust the following parameters:

- Rotation around X-Axis
- Rotation around Y-Axis only slightly with slotted holes
- Forward backward movement by sliding the clamp over the pipe

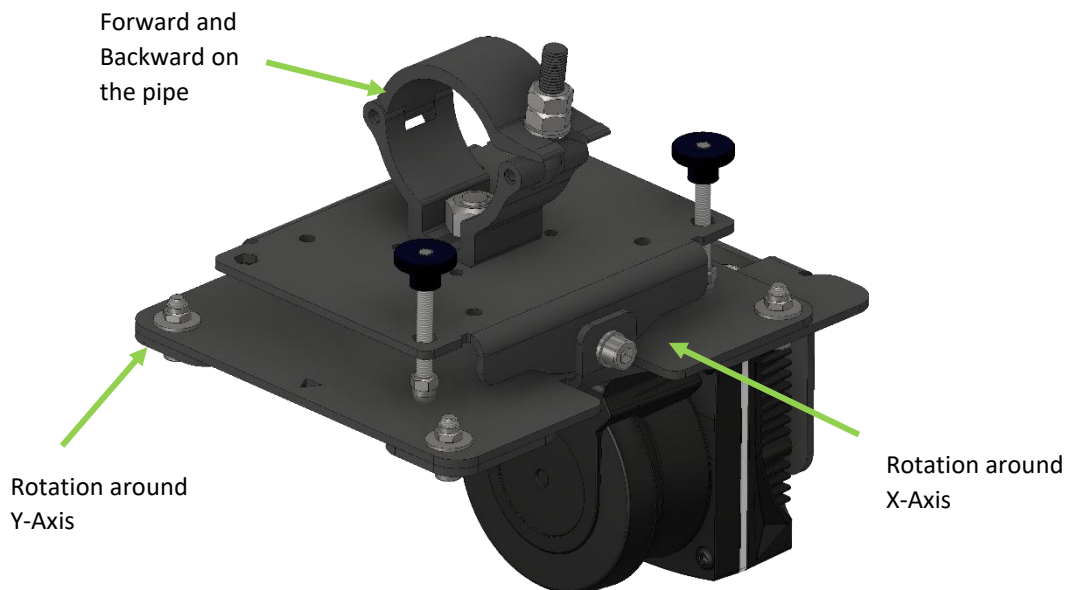

Figure 11 Standard Mounting System

Manual radarTOUCH NEO

To attach the radarTOUCH measurement device to the Standard Mounting System, use the four M5 x 12 DIN 912 screws (see Figure 12).

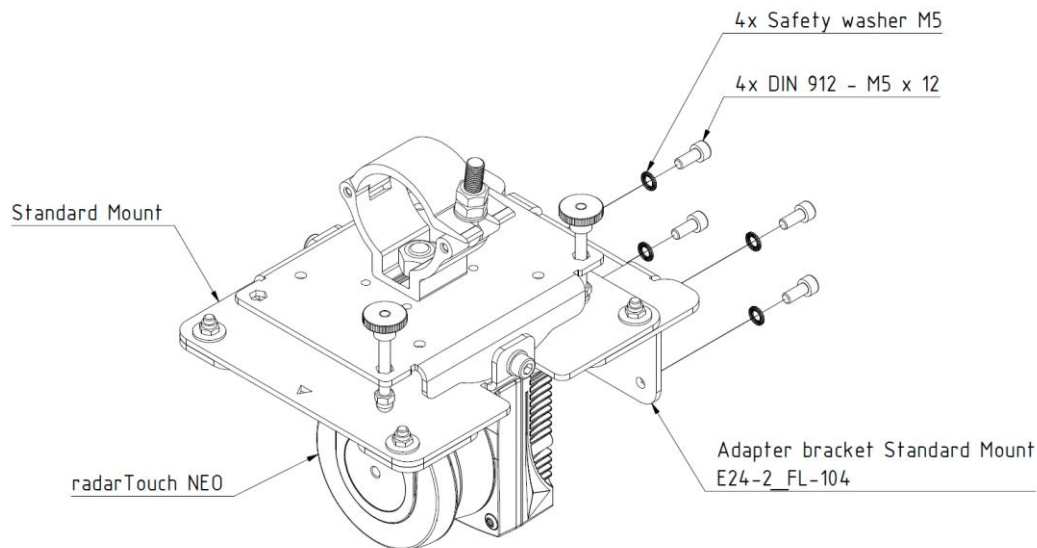

Figure 12 Explosion drawing mounting to Standard Mount

6.2.3 Standard mounting system small



Detailed drawings are available online or on request

The standard mounting system small is a smaller version of the standard mounting system. It offers the same adjustment options. However, if the installation requires a very high precision, you should use the deluxe system.

With the standard mounting system small, you can adjust the following parameters:

- Rotation around X-Axis
- Rotation around Y-Axis only slightly with slotted holes
- Forward backward movement by sliding the clamp over the pipe

Manual radarTOUCH NEO

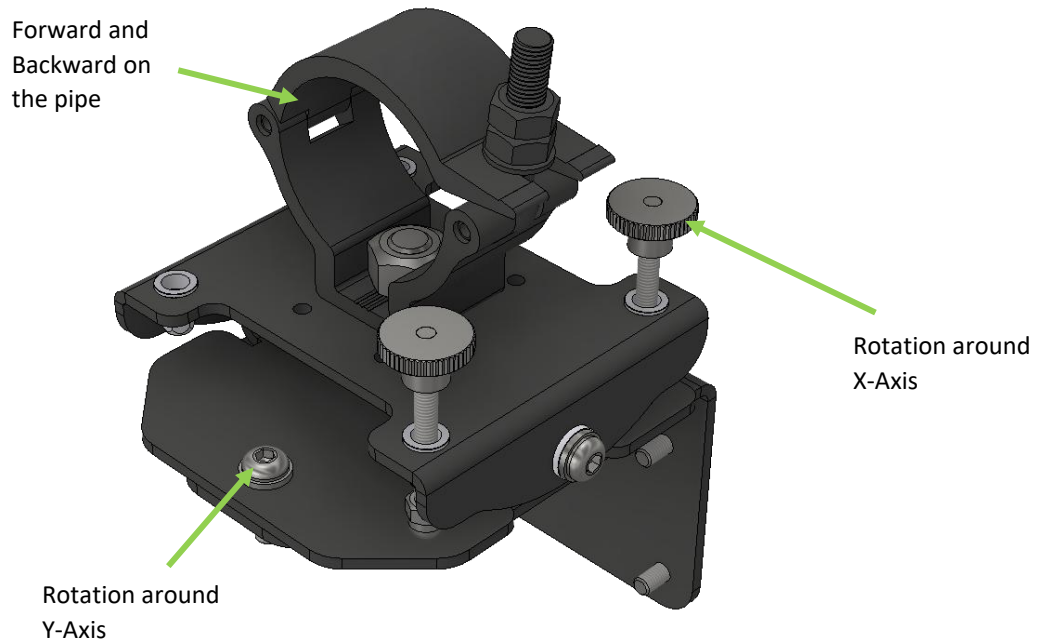

Figure 13 Standard mounting system small

To attach the radarTOUCH measurement device to the Standard Mounting System Small, use the four M5 x 12 DIN 912 screws (see Figure 14).

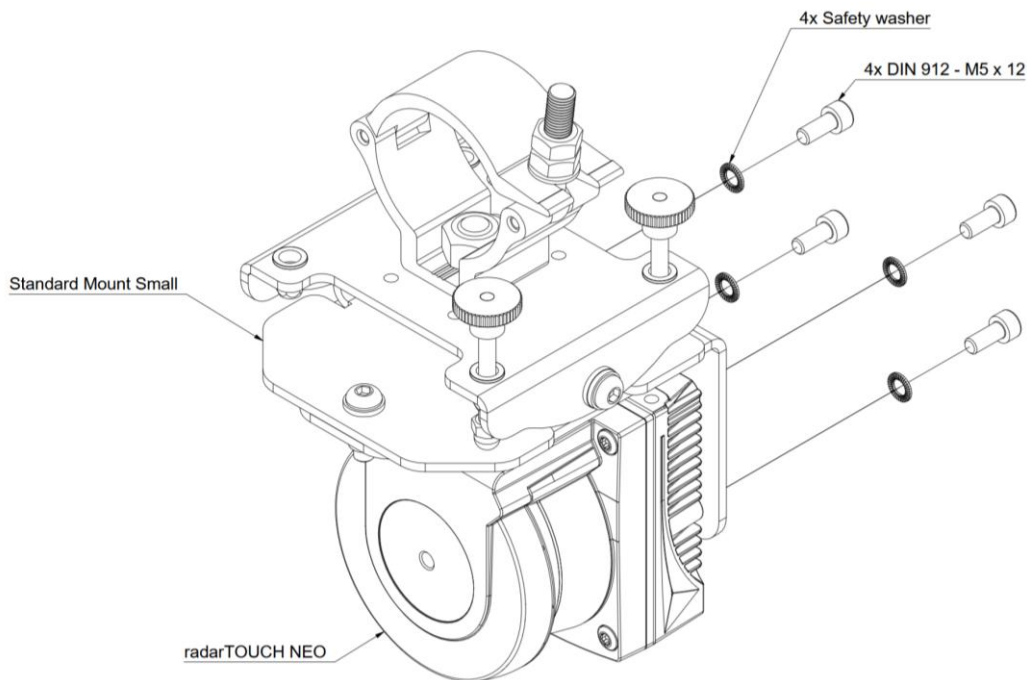

Figure 14 Explosion drawing mounting to Standard Mount Small

6.3 Connection

To run the radarTOUCH software, you need a Windows PC with an installed Java Runtime Environment (Version 1.8, 64 bit). The correct Java JRE is always stored on the USB Dongle.



The radarTOUCH Software will only run if it is started directly from the USB Dongle. You cannot remove the files from the dongle and start them from another location.

Follow the next steps to connect the radarTOUCH hardware with the radarTOUCH software.

- Use the Ethernet cable to connect the measurement with your computer.
- Connect the power supply cable to the measurement device. Plug in the mains adaptor.
- For further information regarding status LEDs please see chapter 5.5 Front LEDs
- Configure your PCs network settings by using a static IP-address 192.168.060.yyy where yyy is a number between 0 and 255.
- Usually, the measurement devices are shipped with the default IP 192.168.060.003. Your computer can set for example to the IP 192.168.060.011 (This is the default OSC client IP to receive TUIO data).
- Start the .exe file on the USB Dongle. The Software will start and automatically build up a connection to the radarTOUCH measurement device.
- If it doesn't start automatically, please have a look at chapter "7.3 How to ping the radarTOUCH" and check the connection between your computer and the measurement device.



(Please refer to chapter "7.1 Changing the IP address of your computer" learn how to change the IP address)

7. The radarTOUCH Software

7.1 Graphical user interface

The graphical user interface (GUI) contains two main windows. The first window, the settings panel, offers the user the possibility to adjust the parameters which affect the way the system works. The second window, the PreViz, shows the measurement data in a pre-visualisation. Figure 1 shows the GUI. In the menu bar you can save your current settings or you can load settings you have done previously. Furthermore, you can turn the PreViz on or off and you can open an Info-Window.

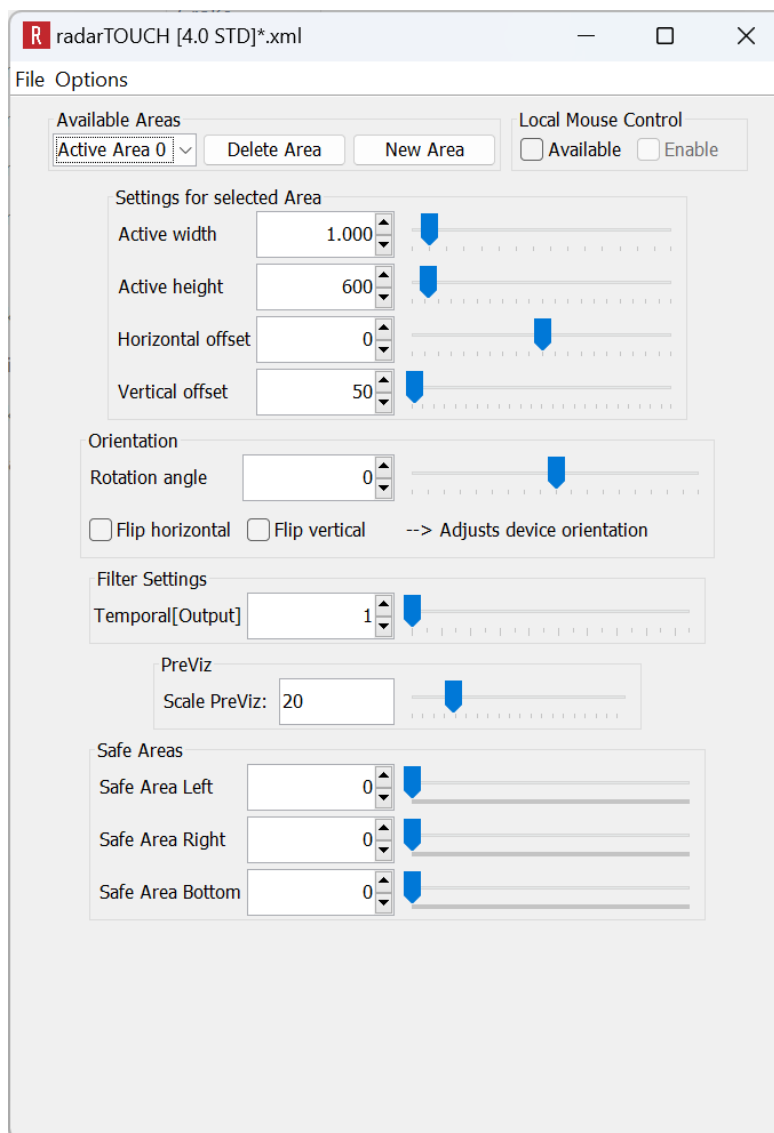

Figure 1 GUI settings

In the upper part of the GUI, labelled as “Available Areas”:

- » You can see all available active areas
- » You can create a new area or
- » You can delete the active area that is selected in the drop-down box.

In the part “Settings for selected area” you can define the size of the **ActiveArea**. The active area is the area in which the system interprets obstacles to touchpoints.

The slider “**Vertical offset**” and “**Horizontal offset**” adjust the vertical and horizontal position of the active area. Please note that the horizontal size increases to both sides equally whereas the vertical size increases only in the distance away from the measurement device.

The next parameters in the settings GUI (**Rotation angle, Flip horizontal / vertical, Scale PreViz**) work in a global way: they have effect on each active area.

By varying the parameter “**Rotation angle**” you can virtually rotate the measurement device. With the use of the check box “**Flip horizontal**” and “**Flip vertical**” you can flip the horizontal and vertical orientation of the device. With this you can define how the device is installed

With the **Temporal[Output]** slider you can adjust the strength of a de-noising algorithm that works only on the detected touch points. If it is set to the value 1, it is set to bypass.

The smoothing value applies to each active area separately and is not a global parameter.

The Slider “**Scale PreViz**” scales the Pre-Visualization.

The **SafeAreas** are split up into “Safe Area Left”, “Safe Area Right” and “Safe Area Bottom”. With them you can create areas at the three named borders of the **ActiveArea** in which no interaction will happen. Those **SafeAreas** are inactive areas and you basically decrease the size of the **ActiveArea** but the mapping of the coordinates is still correct.

Manual radarTOUCH NEO

Creating a new active area

By clicking the “New Area” button a window (Figure 2) will appear, asking you to select an interface. Right now there is only TUIO available. Press next and you can adjust the settings of your chosen interface like OSC Port and the IP address of the receiver (Figure 3).

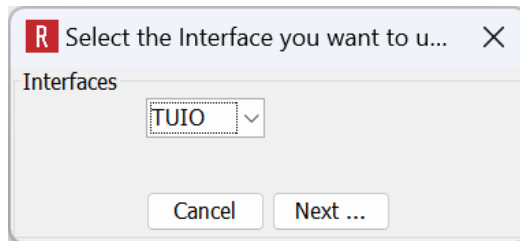

Figure 2 Creating a new active area: Select Interface

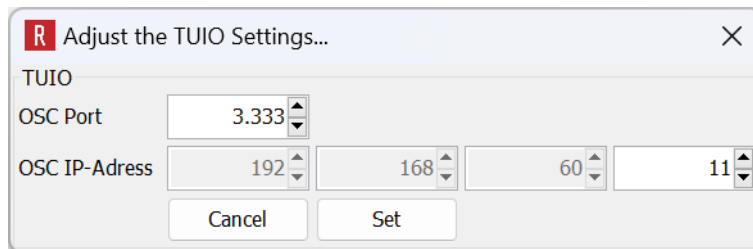

Figure 3 Basic settings for the new active area

Local Mouse Control

By clicking the “Available” check box, the active area that controls the local mouse will appear in the PreViz and in the drop-down box. The ID is always -1. You can adjust all parameters like the way it is done with all the other active areas. If you check the “Enable” box, the mouse will be controlled.

7.1.1 The PreViz

An active area is displayed in the PreViz window as a coloured rectangle. If you move with the mouse over the rectangle, it will show the current settings regarding the IP-Address and the port to which the data is sent. If you click in one rectangle, it will automatically be selected in the settings GUI. Figure 4 shows the PreViz with one active area. Figure 5 shows the PreViz with two active areas. By using Keyboard-Shortcuts you can define what data should be displayed in PreViz Window. To use them, the focus must be on the PreViz.

Here is a short overview:

- m: Draws every 10 measurements the number on the angular element
- g: Draws start and end points of the obstacles

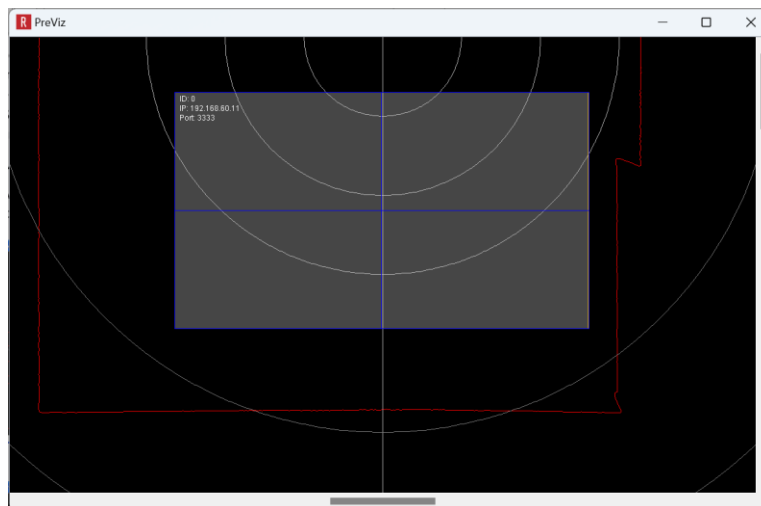

Figure 4 PreViz with one active area

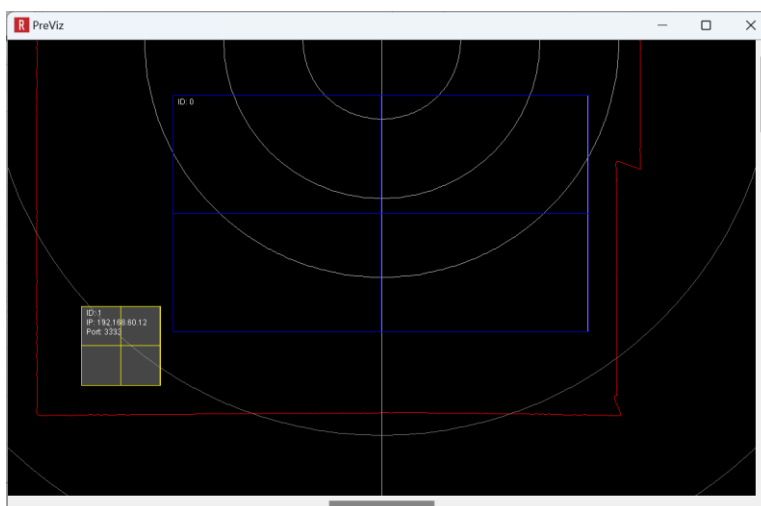

Figure 5 PreViz with two active areas

7.1.2 MultiBlobViz

If you are ready with setting up the active area you can use the test program which will help you to do some fine adjustments. This tool is called “MultiBlobViz”, you will find it under Options→ Start MultiBlobViz.

What it does is to receive TUIO data on port 3333 and draws circles on the corresponding screen position (see also chapter 7.2.2 Open sound control (OSC): TUIO). Make sure that your PC on which you are running the radarTOUCH software, has the IP address to which you are sending the TUIO data.

By using the arrow keys, you can change the position and size of your active area:

- Arrow keys up, down, left, right → Changes horizontal and vertical offset
- CTRL + arrow keys up and down → Changes active height
- CTRL + arrow keys left and right → Changes active width
- L → Toggles between Polyline Path on/off

The small icons in the lower part of the screen will help you during your adjustments. You are only changing the active area which has the focus in the PreViz window. You can leave this application by pressing ESC but keep in mind that you have store your new settings are not stored automatically.

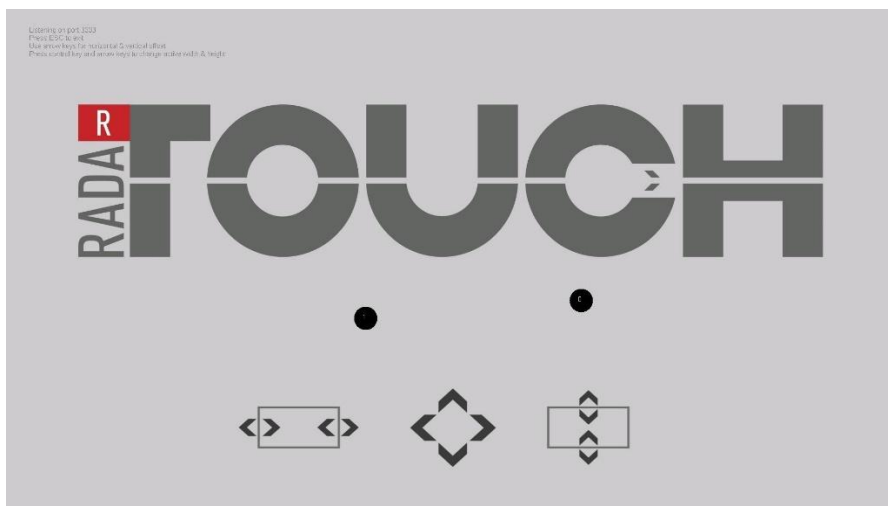

Figure 6 MultiBlobViz test program

The middle of a blob should be the middle of your finger, then the active area was set up correctly. Check the centre and also the borders of your screen.

7.1.3 The Info-Window

The Info-Window (Options → Info) informs you for example regarding network setting and used output interfaces.

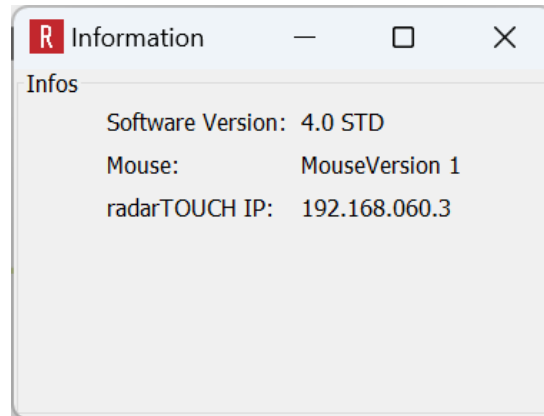



Figure 7 The Info-Window

7.2 Output interfaces

In the radarTOUCH software output interfaces are used to send data of detected obstacles to a receiving software. There are a lot of possibilities to do this. In most cases the radarTOUCH software sends the data via OSC or it simply controls the windows mouse directly. Controlling a windows mouse usually offers only single touch or dual touch interaction. These interfaces will be described in the next paragraph.

 TUIO should be considered as the ideal output interface. Controlling the windows mouse is old fashioned and very limited.

7.2.1 Mouse Emulation

First of all, it is important to know that the radarTOUCH is not a device that can be used as a complete mouse replacement. If emulating a mouse, the software must run on the PC whose mouse shall be controlled. Furthermore, it is important to know how the mouse should react. Shall the left button be clicked and released when entering the active area with an obstacle? Or shall it work like a drag and drop function which keeps the button clicked as long as the obstacle is detected?

7.2.2 Open sound control (OSC): TUIO

OSC is an interface that usually uses the UDP protocol. Data is sent to so called OSC-Addresses. For more information please have a look at <http://opensoundcontrol.org/>. One very popular protocol for multi touch applications is TUIO. It defines different Profiles; we are using the /2dCur Profile. It sends the following data always to the OSC-Address

/tuio/2dCur .

set, s, x, y, X, Y, m

With:

set	→ String that always comes first to indicate which data will follow
s	→ Object ID [int 32]
x	→ x-Coordinate, Range 0...1 [float 32]
y	→ y-Coordinate, Range 0...1 [float 32]
X	→ Movement vector x-Direction (motion speed and direction) [float 32]
Y	→ Movement vector y-Direction (motion speed and direction) [float 32]
m	→ motion acceleration [float 32]

This is sent for each detected obstacle.

alive, [List of all objects alive]

With:

alive:	→ String that always comes first to indicate which data will follow
id's	→ IDs of all detected obstacles

This is sent once for one measurement and includes all active detected obstacles.

For more detailed information please have a look at <http://www.tuio.org/?tuio10>. Everything needed is described there.

7.3 XML Files

There are two different XML files used in the radarTOUCH software which will be described in the following paragraph.

7.3.1 Setting files

The user can store all settings that he has done by using the GUI in an XML file. The software automatically stores one XML file (RadarTOUCH_lastSettings.xml) that keeps track of the last used settings. This file is always located in the same path as the software itself and is loaded automatically on restart if the file is available. Otherwise, the software will start with default values.

This is how a stored file with one active area and disabled mouse looks like:

```
<ns2:settings xmlns:ns2="test">
  <selectedOutputID>1</selectedOutputID>
  <skalierungDerZeichnung>20</skalierungDerZeichnung>
  <rotationAngle>0</rotationAngle>
  <hFlip>>false</hFlip>
  <vFlip>>false</vFlip>
  <interpreterList>
    <activeArea>
      <activeHeight>600</activeHeight>
      <activeWidth>1000</activeWidth>
      <colour>0</colour>
      <colour>0</colour>
      <colour>255</colour>
      <HOffset>0</HOffset>
      <VOffset>50</VOffset>
    </activeArea>
    <smootherLevel>1</smootherLevel>
    <port>3333</port>
    <inetAdress>192.168.60.11</inetAdress>
    <uniqueID>0</uniqueID>
  </interpreterList>
  <selectedInterpreterInComB>0</selectedInterpreterInComB>
  <mouseSettings>
    <activeArea>
      <activeHeight>200</activeHeight>
      <activeWidth>300</activeWidth>
      <colour>255</colour>
      <colour>0</colour>
      <colour>0</colour>
      <HOffset>0</HOffset>
      <VOffset>50</VOffset>
    </activeArea>
    <smootherLevel>1</smootherLevel>
    <uniqueID>-1</uniqueID>
    <mouseEnabled>>false</mouseEnabled>
  </mouseSettings>
</ns2:settings>
```



Note: If you ever wish to reset to default values, delete the lastSetting.xml file and restart.

7.3.2 Configuration file

There are a few settings that are typically not often changed. If the user needs to change them, he can open the RadarTOUCH_Config.xml with a text editor, for example word pad, and change and save the parameters. The software needs to be restarted to use the new configuration file.

Here is an overview of the parameters:

```
<ns2:configSettings xmlns:ns2="config">
  <radarTouchIP>192.168.060.004</radarTouchIP>
  <oscClientIP>192.168.060.011</oscClientIP>
  <mouseVersion>1</mouseVersion>
  <allowStartingTwice>true</allowStartingTwice>
  <startMinimised>false</startMinimised>
  <wideWorkingRange>false</wideWorkingRange>
  <minObjectSizeIs_1>false</minObjectSizeIs_1>
  <flipXandY>false</flipXandY>
  <maxDistance>0</maxDistance>
  <maxAngularDistance>0</maxAngularDistance>
  <radarDROIDactive>true</radarDROIDactive>
  <radarDROIDport>3335</radarDROIDport>
  <trackingSettings>
    <factorSimilarityThreshold>40</factorSimilarityThreshold>
    <weightDistance>200</weightDistance>
    <weightMoveVec>400</weightMoveVec>
    <weightPredict>200</weightPredict>
    <weightSize>100</weightSize>
  </trackingSettings>
</ns2:configSettings>
```

Manual radarTOUCH NEO

radarTouchIP

The software has to know which IP the measurement device is using. This can be set with this parameter. For changing the IP address of the measurement device please refer to chapter 8.1 Changing network settings.

OscClientIP

This is the IP that is as default set in the interface settings dialog that is shown in Figure 3.

MouseVersion

This Integer value defines the mouse version that is used if mouse emulation is activated. Mouse emulation can be done in various ways, it is important to test applications if the mouse emulation works the way it is needed.

Currently there are three different versions implemented:

mouseVersion == 1

This Version keeps the left mouse button clicked as long as the obstacle stays in the active area. If the system detects two obstacles, it scrolls the mouse wheel up or down depending on a changing distance between the two obstacles. With this, some sort of zoom gesture can be used.

mouseVersion == 2

This version does a single click and a double click depending on the time between two new obstacles. If the system detects two obstacles, it keeps the left mouse button clicked.

mouseVersion == 3

This Version keeps the left mouse button clicked as long as the obstacle stays in the active area. Compared to version 1, it does not scroll the wheel if two objects are detected. No matter how many objects are detected, it simply tracks on the first obstacle that was detected and follows it with the mouse.

allowStartingTwice

Usually the software cannot be started twice. For some reason it might be needed to run the software two times on one computer. This can be done with setting this parameter to true. Know you cannot connect two times to one radarTOUCH measurement device. If you want to use two units, you must change the IP address. For this please refer to chapter 8.1 Changing network settings.

startMinimised

If this Boolean variable is true, the GUI starts minimised to the task bar.

Manual radarTOUCH NEO

wideWorkingRange

If you want to use the radarTOUCH in very large distances (>12m), you should set this parameter to true. It has the effects on the software that the range of the sliders in the GUI is larger:

Active Width	Normal:	0 – 15.000
	Wide:	0 – 100.000
Active Height	Normal:	0 – 10.000
	Wide:	0 – 50.000
Vertical Offset	Normal:	0 – 6.000
	Wide:	0 – 50.000
Horizontal Offset	Normal:	-2.500 – 2.500
	Wide: -	25.000 – 25.000

minObjectSizeIs_1

Just like the parameter above, this is useful if you use the radarTOUCH in very large distances. If you are not using the device that way it should always be set to false.

flipXandY

If this parameter is set to true, the x- and y-coordinates in the TUIO data are flipped. That means x becomes y and y becomes x.

maxDistance and *maxAngularDistance*

Sometimes it is useful to reduce the resolution which the radarTOUCH offers. Some users point with their hand at a button and not with just one finger. If they use the hand, the system might detect a few more blobs than just one. This might trigger some wrong events. You can reduce the resolution by setting these two parameters higher than zero.

maxDistance

Describes the maximum distance in mm for two obstacles to be detected as one.

maxAngularDistance

Describes the maximum distance angular measurements that could be between two obstacles to be detected as one. If both parameters are set to zero, the system uses the normal algorithm for detecting obstacles. If you choose to use them, the system uses a different algorithm that has its strengths performing some sort of a blob reduction.

trackingSettings

You should not change anything here!

8.0 Configuration Tool

The Configuration Tool is an additional tool that is used to configure the measurement device.

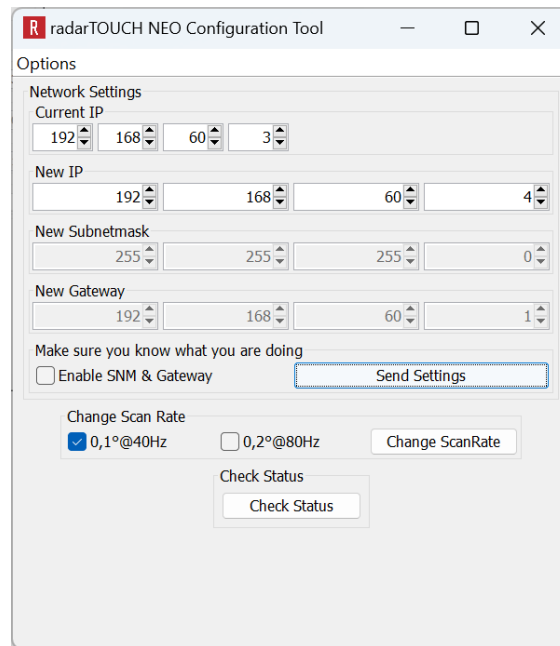

Figure 15 Configuration Tool

8.1 Changing network settings

Figure 15 shows the GUI of the tool. For setting up the network configuration, you will find the following parameter:

- Current IP: IP address that the device currently has
- New IP: IP address that you want to assign the the device
- New Subnetmask: Subnetmask that you want to assign the the device
- New Gateway: Gateway that you want to assign the the device



Note: If you want to edit SNM and Gateway, you have to Enable it with the corresponding checkbox. If you wish to do so, make sure you know what you are doing.

Press “Send Settings” button if you want to send the network settings to the device.

8.2 Changing angular resolution and scan frequency

You can also change the angular resolution and scan frequency. There are two options as can be seen in Figure 15.:

- 0,1° with a scan frequency of 40 Hz
- 0,2° with a scan frequency of 80 Hz

In most cases the 0,1° at 40 Hz should be fine. However if reaction time is important, you can change the parameters here.



Note: Make sure the correct IP address of the device is entered under “Current IP”.

8.3 Check Status

By pressing the “Check Status” button, you can query some information from the device as can be seen in Figure 16.

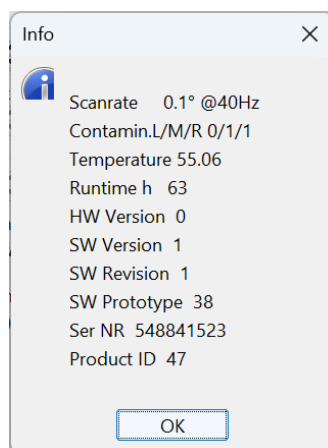

Figure 16 Check Status

Contamin. L/M/R Contamination of the front window on left, middle and right side.
Values from 0 to 100. See also chapter 5.5 Front LEDs

Temperature: Temperature in °C



Note: Make sure the correct IP address of the device is entered under “Current IP”.

8.4 Reset Network Settings

In the top menu you have an option to reset all Network Settings. This might be useful if you do not know the current network settings of the device. This works via USB C connection. To get access to the USB socket, remove the front cover which is marked with the USB sign, see green circle in below figure. Connect the device with you PC via USB C cable.

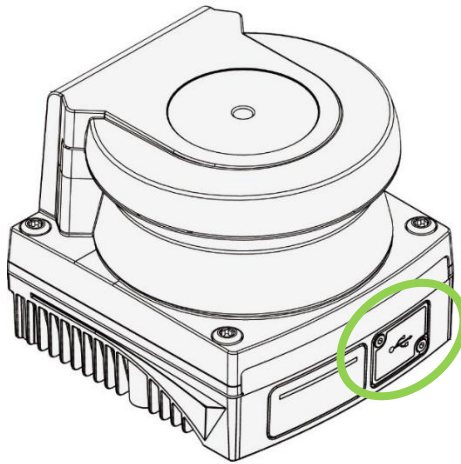

Figure 17 USB socket behind cover

Once connected, go to Options Menu and press “Reset all Network Setting”. After this you will be asked if you really want to reset. If the device is found and reset was successful, you will get a success message.

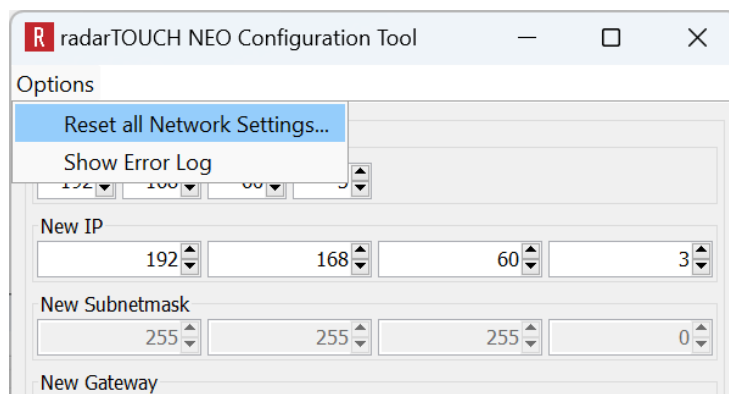

Figure 18 Reset all Network Settings



Note: Make sure to properly reinstall the front cover otherwise the device will have no longer any IP protection.

8.5 Get Error Log

In the top menu you can ask the device for its error log. Once pressed it will be displayed as can be seen in Figure 20. The meaning of the error code can be checked in Table 1. The column “operating days” gives an indication how many operating days ago this error happened.

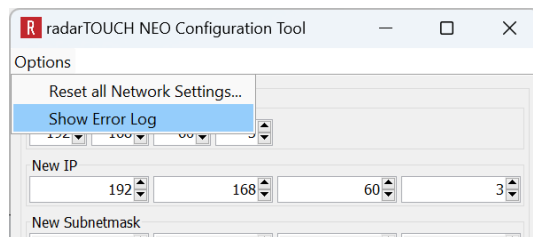

Figure 19 Get Error Log

The screenshot shows a window titled "Error Log" containing a table with two columns: "Error Code" and "Operating Days". The data in the table is as follows:

Error Code	Operating Days
510	0
402	0
510	1
402	1
405	2
322	2
510	2
402	2
109	2
0	0

Figure 20 Result example of error log

Error Code	Description
101 - 110	Internal error
112	Internal voltage error
114 - 133	Internal error
134 - 135	Internal temperature error
136 - 146	Internal error
201	Power supply error
202	Internal temperature error
205-206	Internal temperature error
207	Internal error
208	Internal temperature error
307	Internal communications error
322 - 324	Internal communications error
402	External error
405	External error
510	Ethernet error
999	Unknown error

Table 1 Error Codes

9 Integration

9.1 Best way of mounting

The measurement device should be mounted with minimum 35 cm below or above the image area. Usually, the best position is above the screen.

If a high accuracy is needed the laser should scan as close as possible over the image area to avoid parallax errors as indicated in below illustration (scanner here below the image area).

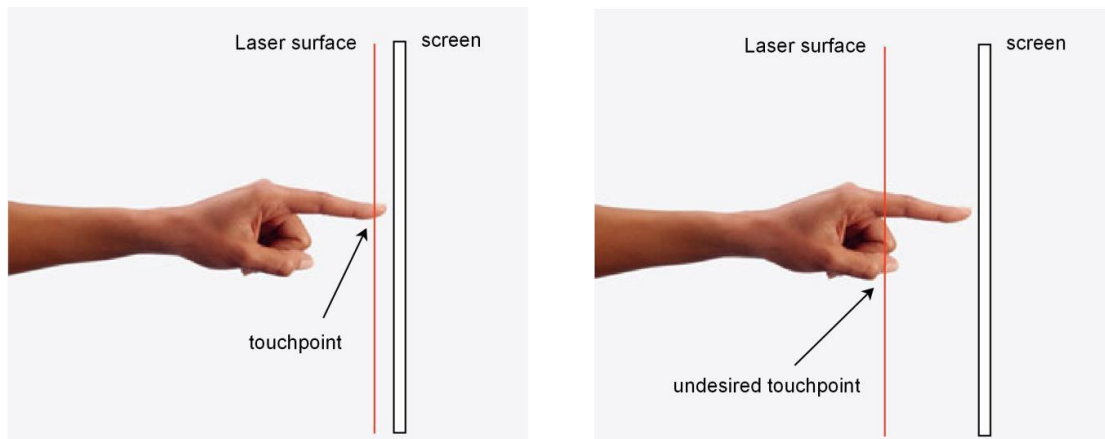

Figure 21 Parallax error illustration



Avoid something like an additional frame that is in front of the image area as this would increase the distance between the laser and interactive surface.



Avoid any reflective materials in the laser scan area as this could cause disturbance and false data. Ideal materials surrounding the laser scan area are matte black.



Surrounding surfaces like walls, ceilings, floor etc can have a disturbing effect on the precision of the measurement data if too close to the interactive area. This is due to the fundamental working principle of the measurement device. A safe area of min. ca. 35 cm space should be considered but double checked for your individual installation. The so called “Safe Areas” (see also 7.1 Graphical user interface) are a way to work around this but with decreasing the actual interactive area.

As a summary see Figure 22.

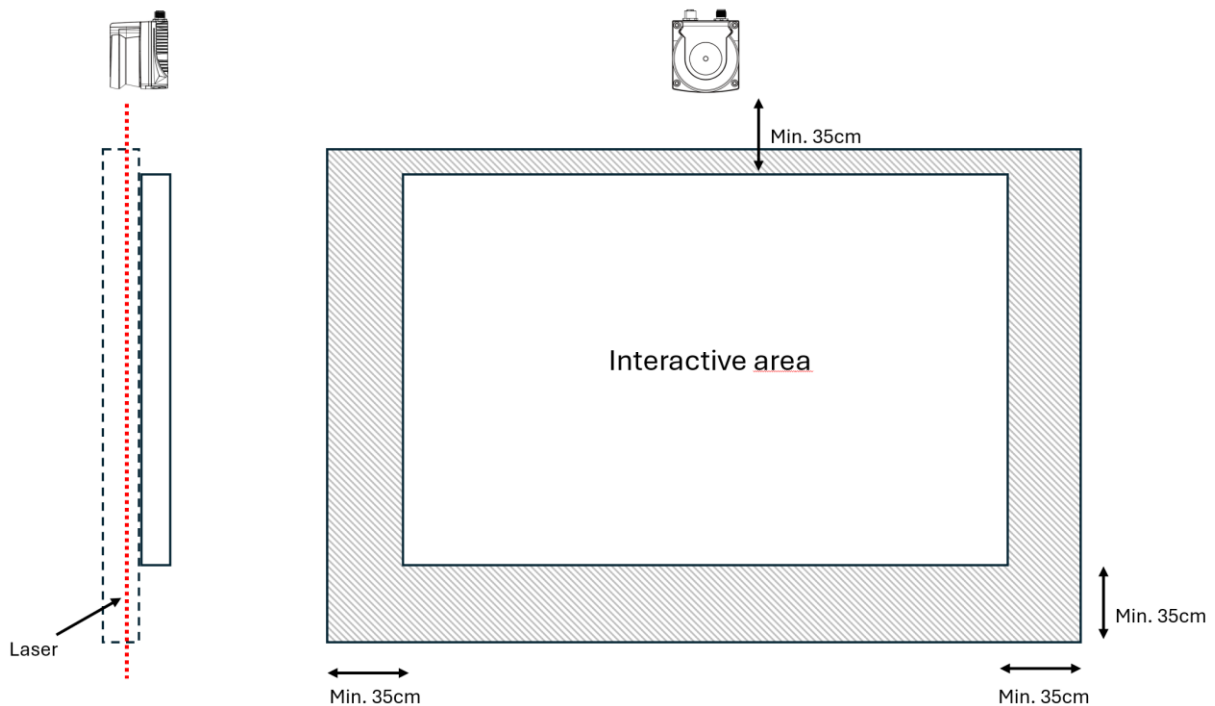

Figure 22 Save areas and correct positioning

One radarTOUCH can cover an area with a size of ca. 10 m theoretically. But note that the resolution and the object recognition decrease with increasing distance. Within this area you can create 10 active areas that send the TUIO data to different IPs. So, it is possible to feed multiple PCs or software applications with one radarTOUCH.

- i** The more precisely the active areas are configured, the higher is the accuracy of the touch coordinates.
- i** It is possible to use more than one radarTOUCH system for one application to cover very large areas or to get a higher resolution. To combine the active areas from the different devices, there is a solution called radarSTITCHER, please contact us for more information.
- i** radarTOUCH can only be calibrated to rectangular screens. If using for example a rear projection as screen, make sure the image is rectangular and not geometrical deformed.

9.2 Concealing the measurement device

If necessary the radarTOUCH measurement device can be covered. But the laser has to be able to scan unopposed through this cover. The depth of front glass must be uncovered. Please consider any adjustment movements of the measurement device during setup. The length of the opening in the cover can be determined in a drawing and depends on the position of the measurement device as well as the position and size of the interactive surface.



The inside of the cover should be painted in a matte black colour.

9.3 Calibration and Adjustment

The precision of the touch depends on the mechanical installation in combination with adjustments in the software. This is an iterative process where technicians have to switch between mechanical and software adjustments to refine the installation.

In general, you want the laser scanning as close as possible to the front of your interactive surface to avoid parallax error.

Start adjusting the interactive area in the radarTOUCH driver. A best practice is to start with the border facing the measurement device.

Example: If the measurement device is fixed below a display, then you start with the lower border or rather with the lower corners of the display image area.

First place an object, for example your finger, in one corner and then in the other corner and watch in the PreViz where your finger is in the software

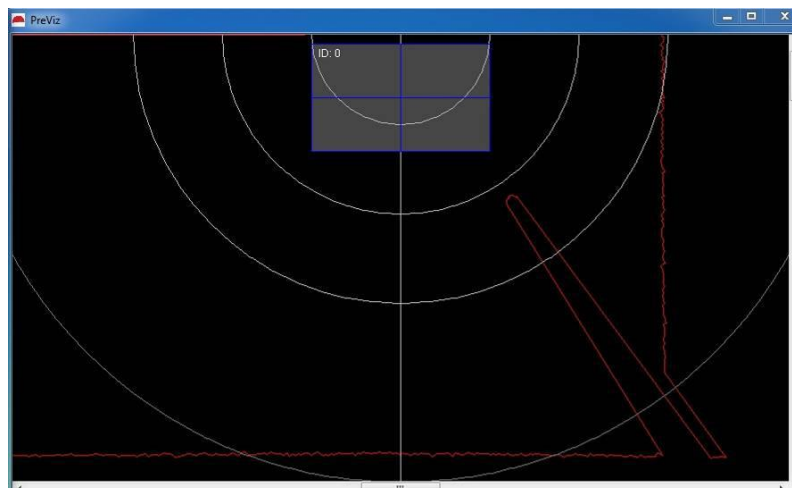

Figure 23 Finger in the PreViz

Manual radarTOUCH NEO

Now position the Active Area with „Vertical offset“ and „Active width“ / „Horizontal offset“ until the corners of the image area match with the corners of the Active Area. The green circle shows that an obstacle is detected. The corners of the Active Area should match with the middle of the circle.

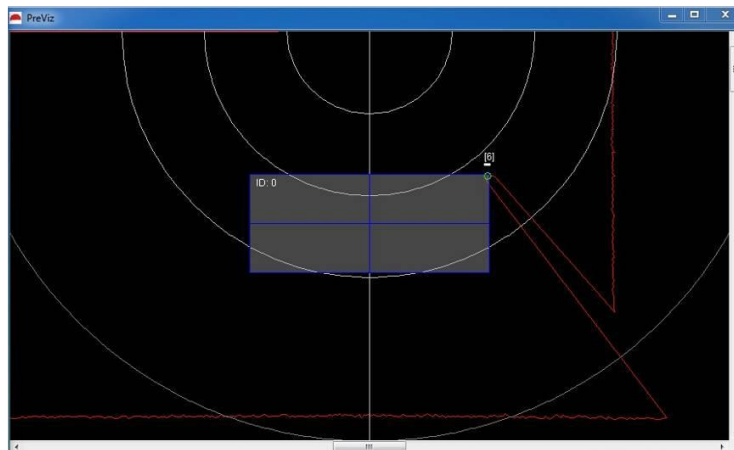

Figure 24 First corner adjusted

Now you can adjust the height of the Active Area with „Active height“. In this case the corners of the image area have to match with the corners of the Active Area, too.

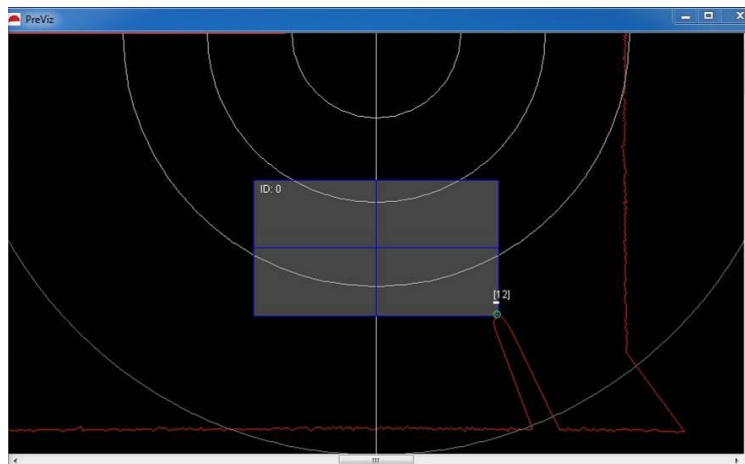

Figure 25 Third corner adjusted

If the measurement device is not centred above or below the image area, you can adjust the Active Area with „Horizontal offset“ accordingly. You need to check if the rotation of the device is mechanically correct. If you can't match all four corners correctly, this might be the reason. It is easier to calibrate the radarTOUCH with two persons, one person handles the PC and the other person stands at the image area.

10 Appendix

10.1 Changing the IP address of your computer

To change the IP address of your Windows 11 computer please connect the radarTOUCH measurement device to the power supply and connect it with the Ethernet cable to the computer.

- Press Windows + R
- Run Shell opens, type here “ncpa.cpl”

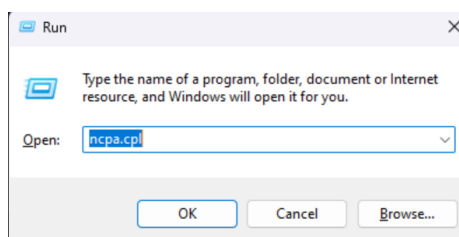

- Network settings open. Choose the network connector that you are using. Make a right click on the correct adapter and go to > Properties,,

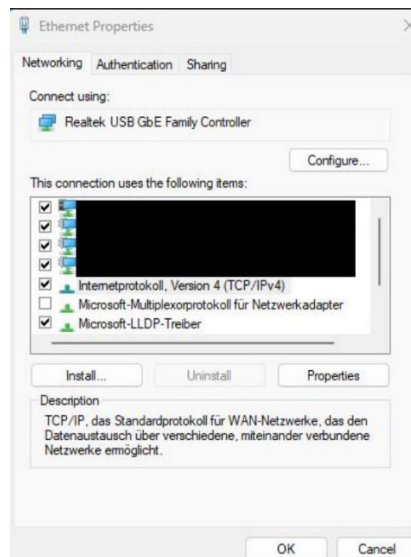

- Choose the TCP internet protocol and click on Properties
- Now you can give your computer a static IP address or change it:

Manual radarTOUCH NEO

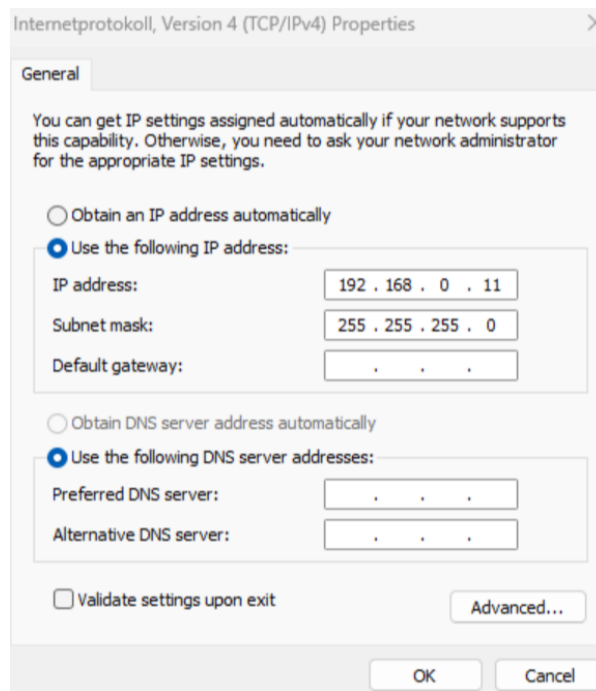

- Confirm your settings and close the Network Places

10.2 User interface design

There are some design rules that have been proven to be useful in the past. Below points summarize some of them:

- Designer / Developer should have access to a radarTOUCH to test their software. A small desktop touch screen behaves differently than a 10m LED wall with radarTOUCH
- If implementing a click gesture on for example a button make sure to understand what triggers the click action. This is usually defined by the time (Δt) and the distance (Δx) between the touch down and touch up event. If time and/or distance is above a certain threshold, the click will not be triggered. Both are usually larger for radarTOUCH compared to conventional devices.
Instead of listening to a single click, a good design practice is to listen to an event like “touch enter” where your front end software recognises if a touch point enters for example a button. In that case wait for example 0,1 sec and if the touch point is still on the button, trigger an event (button clicked). This will create very robust interfaces.
- No double click, does not make any sense
- The graphics should have a certain size to avoid frustration. It is difficult to define a size as this depends on some variables. What you can do is to create an invisible but interactive bounding box around the visible touch elements. This will make the buttons etc still look not too big but interactivity robust. Obviously, there must be enough space between the interactive elements.
- Rotating gestures are difficult as the sensor can lose track of the touch points as one will create a shadow on the other. From our experience this is not a problem as rotating gestures rarely make sense in such setups.

11 Disposal of components

11.1 Metal parts and packaging

All metal parts and packaging can be recycled.

11.2 Disposal of entire devices

You have the possibility to send old devices back to us. Please note that you have to take over the transportation costs for this. Please send the devices to:

EXACT solutions GmbH

Lustheide 85

51427 Bergisch Gladbach

GERMANY

Imprint

EXACT solutions GmbH

Lustheide 85

51427 Bergisch Gladbach

GERMANY

Tel.: +49 2204 9485 30

E-Mail: info@exactsolutions.de

Web: www.exactsolutions.de